

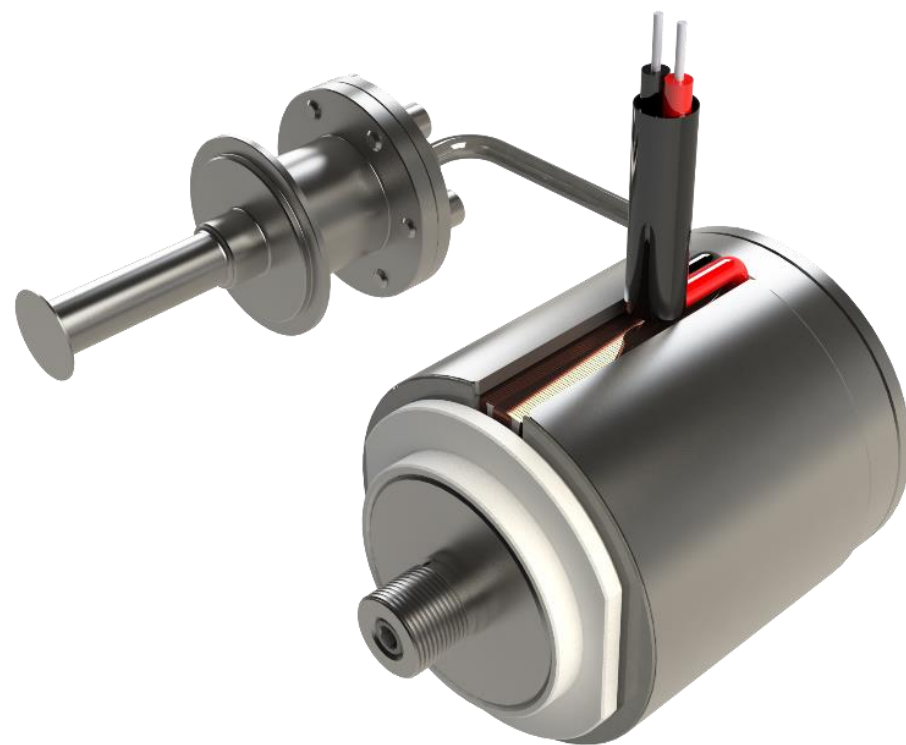

Dec 7-10, 2020

# AFFORDABLE CRYOCOOLERS FOR COMMERCIAL INFRARED IMAGING

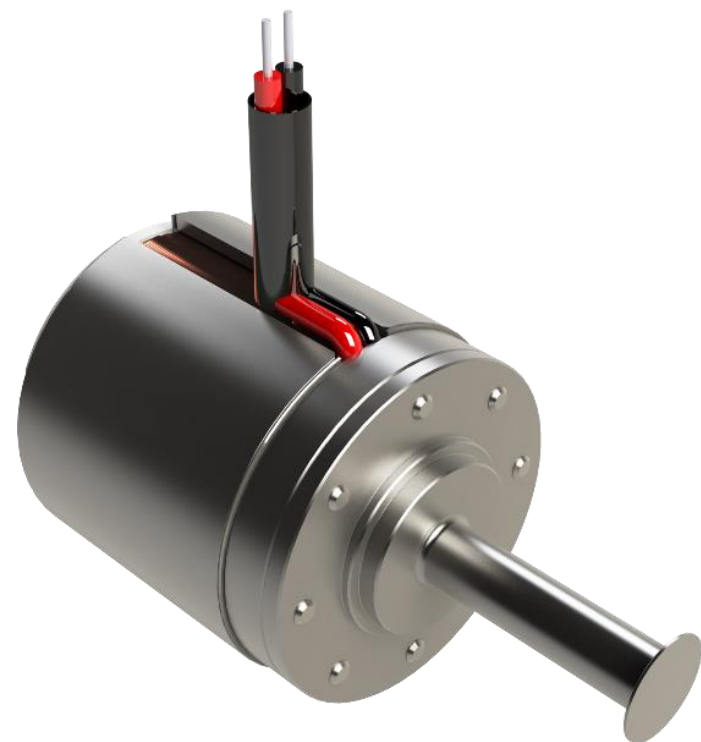

A Veprik, S Zehctzer, A Daniels, R Refaeli and A Wise

CRYOTECH LTD, GEVASOL GROUP, Israel

# OUTLINE

- INTRODUCTION
- A LITTLE BIT OF HISTORY (May 2018-Oct 2020)
- PRESENT STATUS (Dec 2020)
- DESIGN FREEZE – V.4
- VIBRATION ISSUES
- WAY FORWARD

# INTRODUCTION

- Cryogenically cooled vs uncooled IR detectors
  - Longer detectability distances
  - Better temperature and spatial resolution
  - Ability to detect/observe/track fast moving objects
  - Less demanding optics
- Military graded mechanical cryocoolers
  - Low quantities
  - High ownership cost (buying, complicated IDDCA integration and replacement)
  - Tough export regulations
- Emerging commercial marketplace calls for affordable cooled IR imaging
  - High quantities
  - Uncompromised cost, SWaP, life span, ease of integration, vibration export
  - Relaxed export regulations - “specially designed” concept

## TYPICAL MILITARY GRADED SPLIT STIRLING CRYOCOOLERS

- Dual – piston compressor
- Side-by-side packaging
- Pneumatic expander - short cold finger & massive warm side

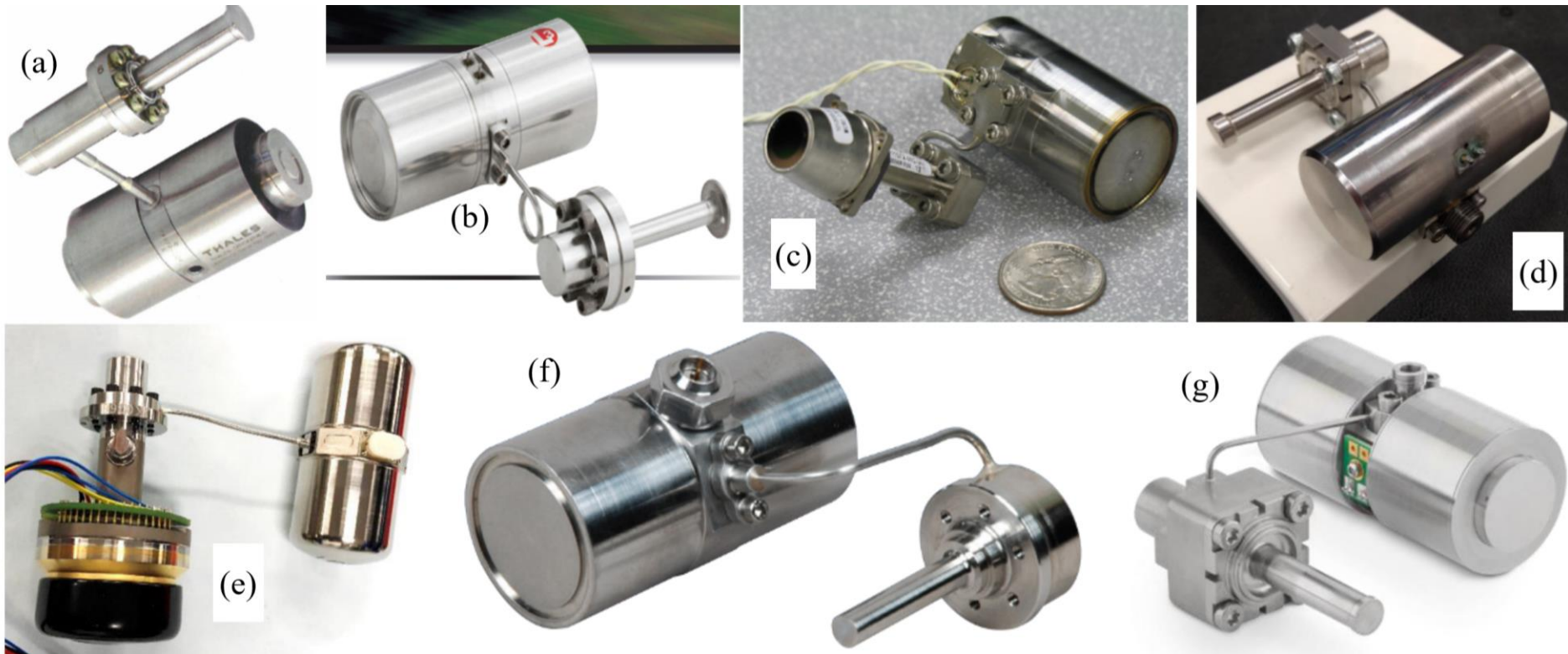

Thales UP8197 (a), L3 L200 (b), DRS microIDCA (c), Ricor K588 (d), FLIR FL-100 (e), Cobham LC1076 (f), AIM MCC025 (g).

## COST REDUCTION

- Price goal: \$XXX at 10,000/ann factory aggregate
- Design to cost:
  - KISS – “Keep it simple, stupid!”
  - single-piston compressor
  - relaxed mechanical tolerances
  - cost effective materials
  - mass production methods for parts manufacturing, assembling, inspection and testing
  - cost effective purge/fill, sealing and characterization procedures

## A LITTLE BIT OF HISTORY

Milestone	Planned	Actual
Kick off	May 2018	May 2018
R&D lab establishment, staffing	Jan 2019	Feb 2019
Prototypes design, manufacturing, assembly and “first ice” observation	Aug 2019	Aug 2019
Optimization for “open air” minimum temperature, mechanical stability issues	Nov 2019	Dec 2019
Redesign towards integration with simulation Dewar (split only)	Jan 2020	Jan 2020
Integration with simulation Dewar	May 2020	Aug 2020
Characterization and optimization	Sep 2020	Nov 2020
Design freeze	Dec 2020	

## INTEGRAL DESIGN V.1

200 gr



### Pros:

- Compactness
- Robustness
- Less weight
- Less power consumption
- Zero vibration moments

### Cons:

- Enlarged optical size
- Less packaging flexibility

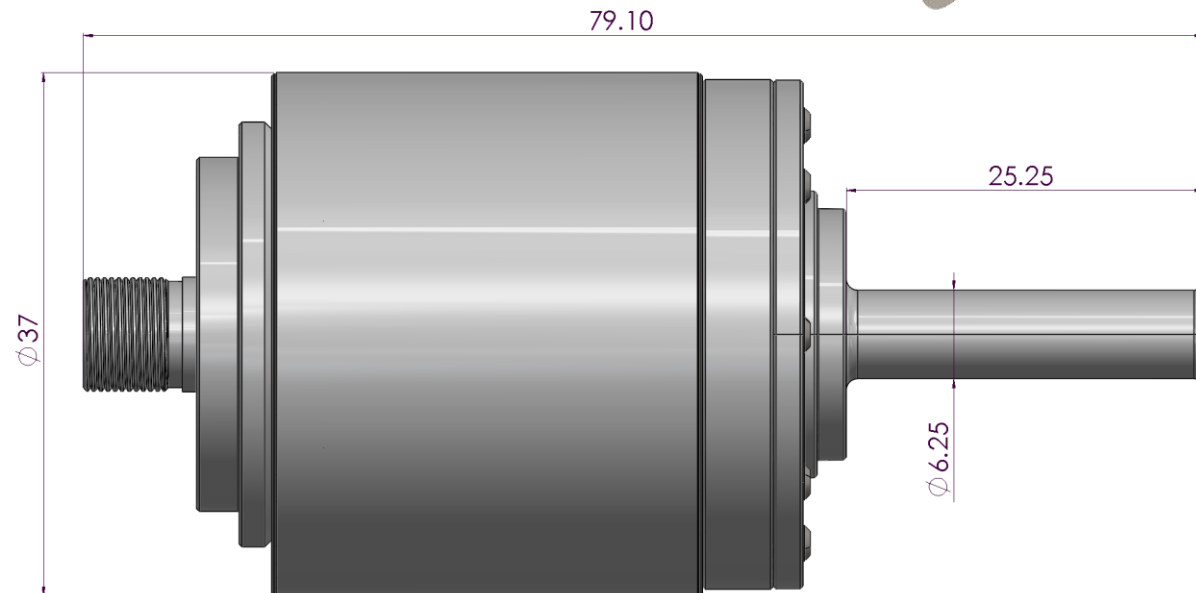

# SPLIT DESIGN V.1

200 gr (compressor) + 30gr (cold head) with monolithic Ti cold finger

Pro:

- Packaging flexibility

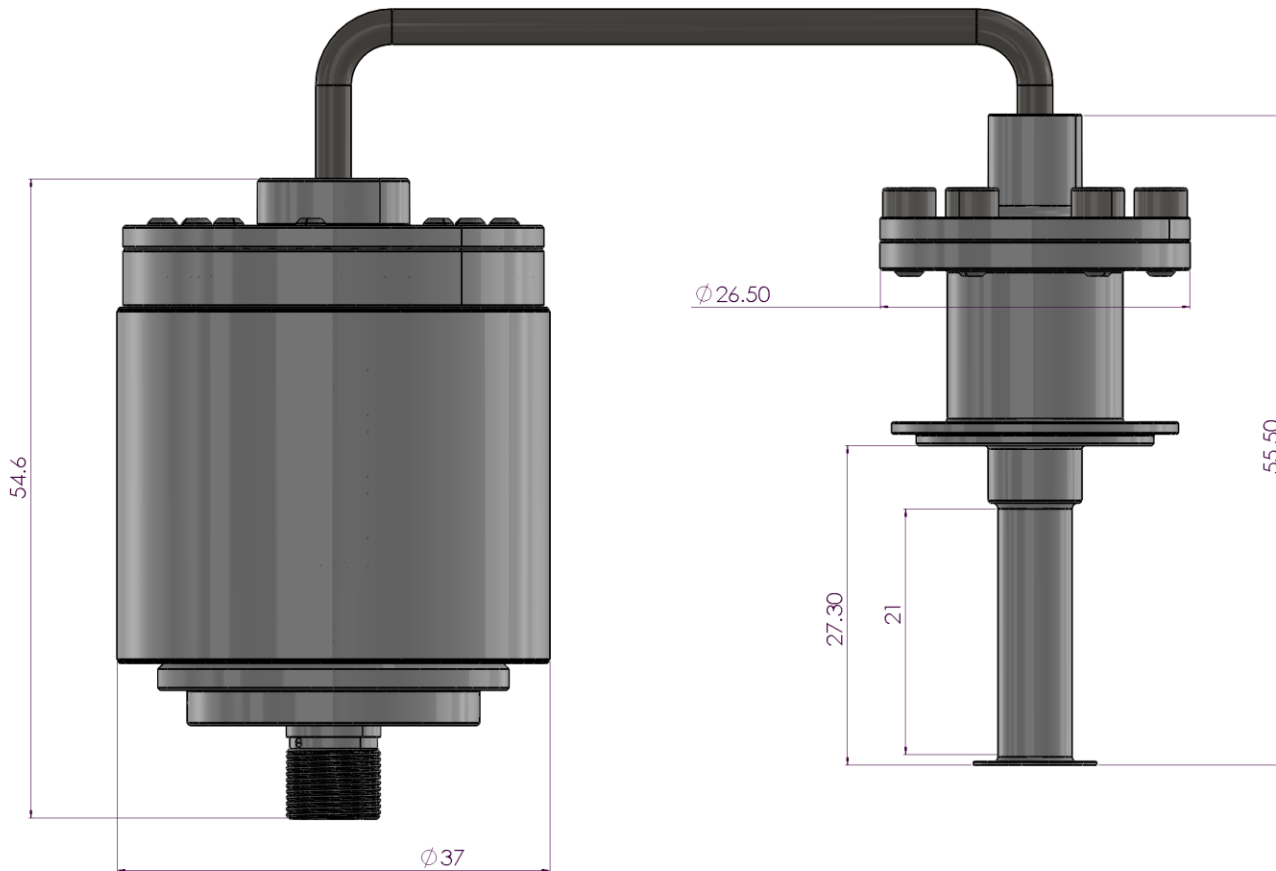
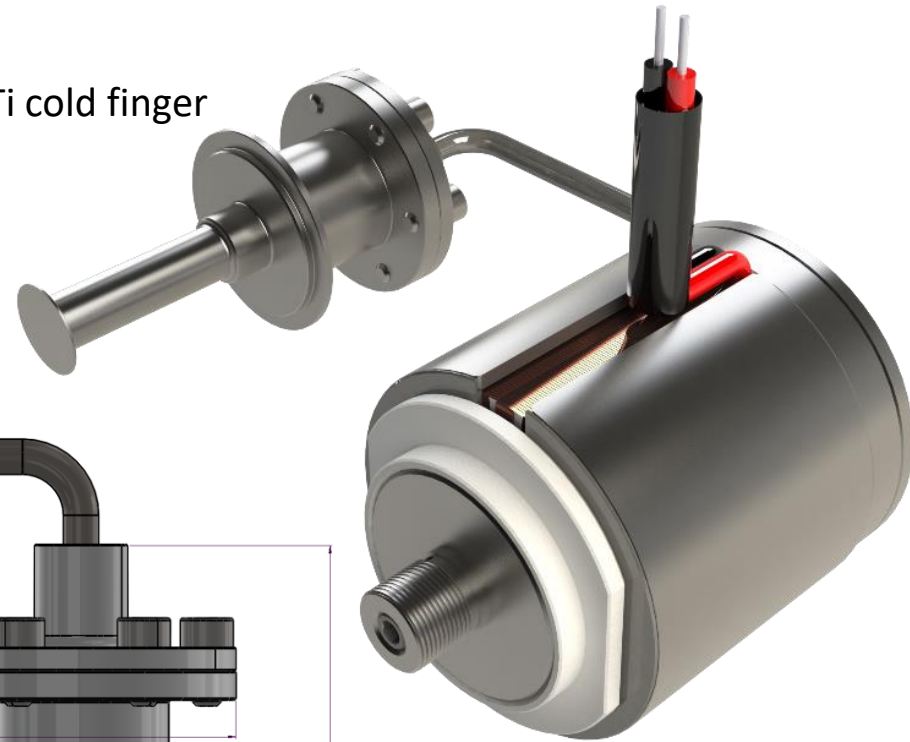

# FIRST FROST- AUG 2019



# SPLIT COOLER V.2

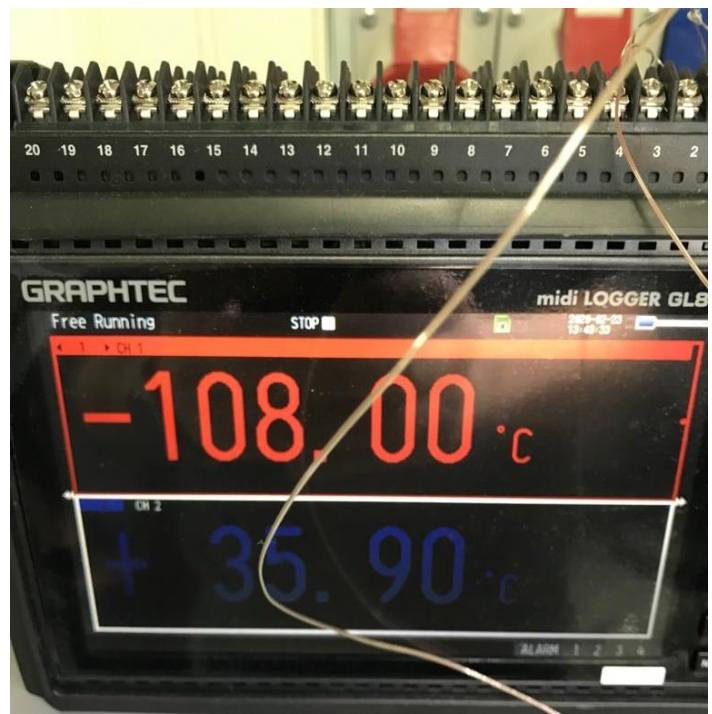
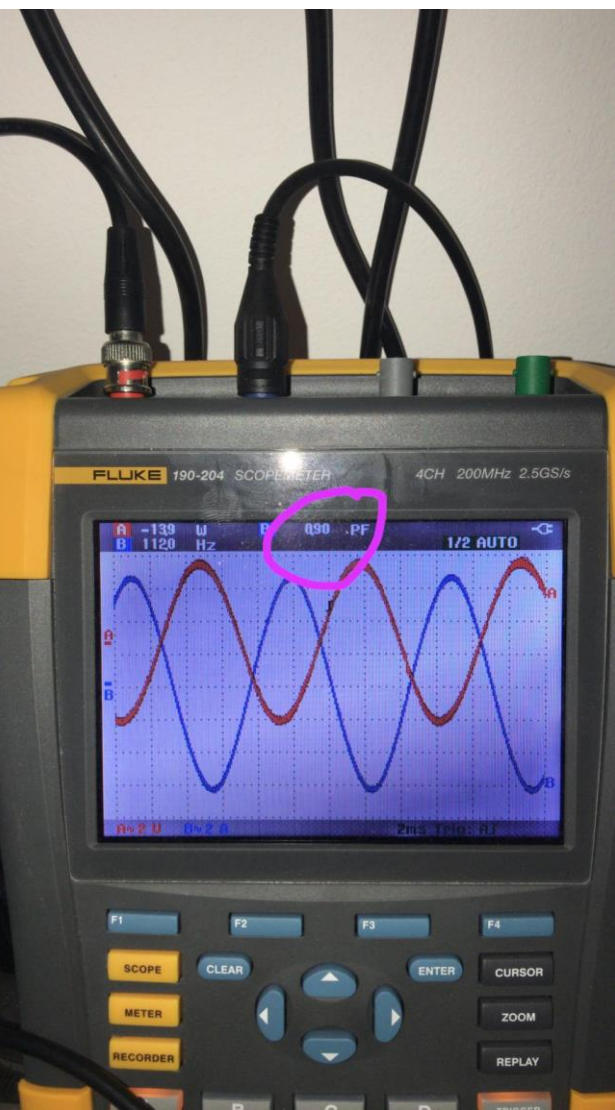

# INTEGRAL COOLER V.2

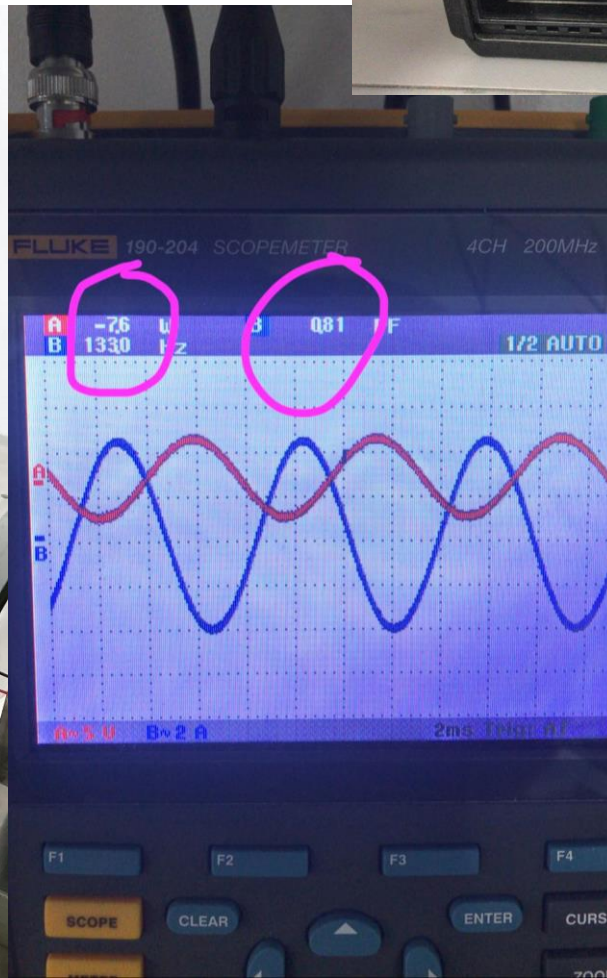
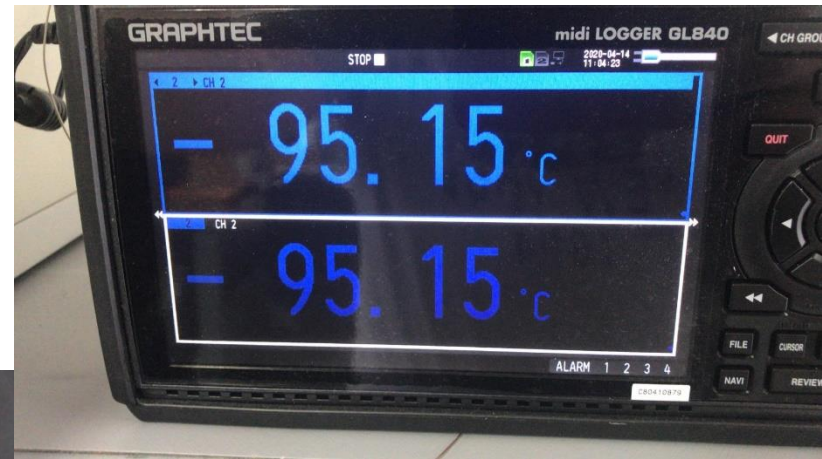
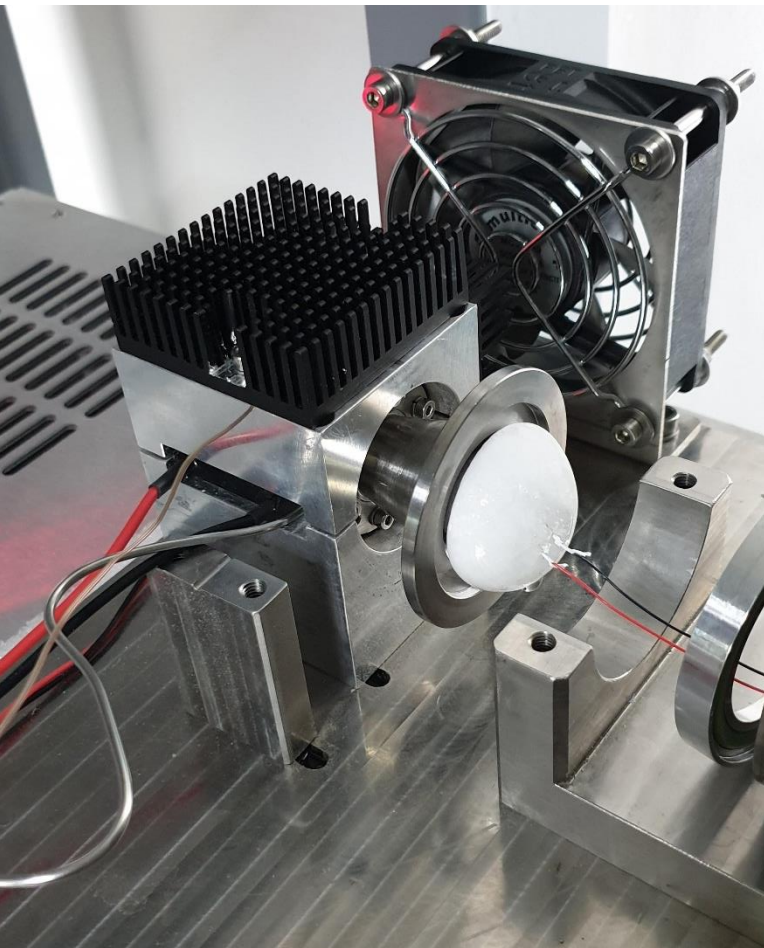

# SPLIT V.2 PERFORMANCE IN VACUUM

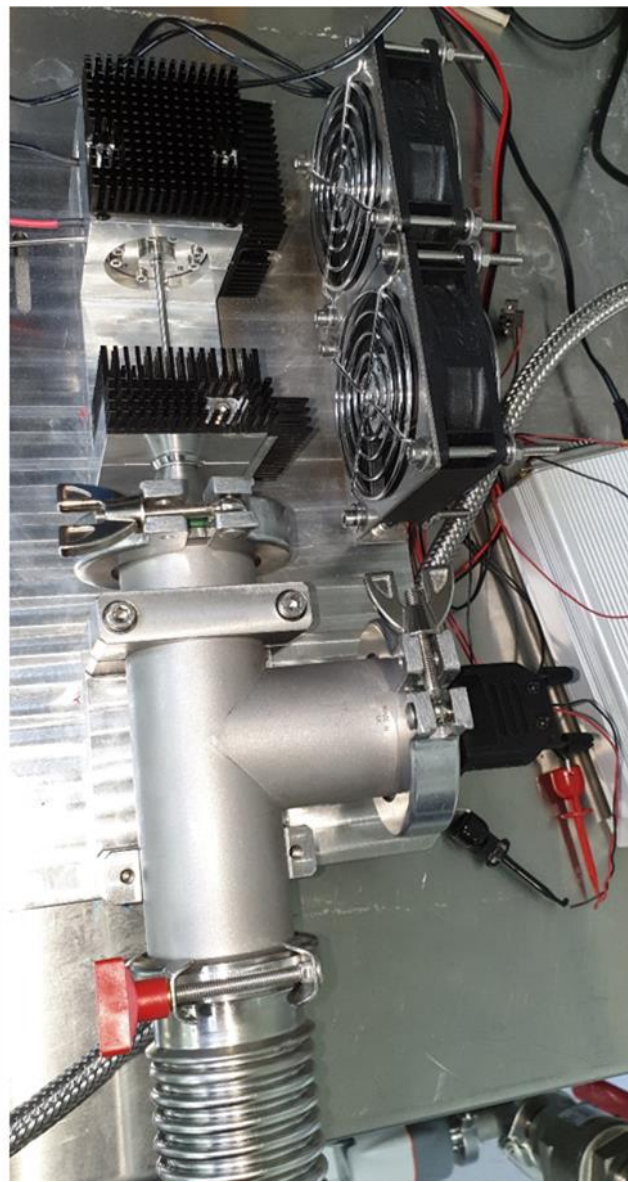
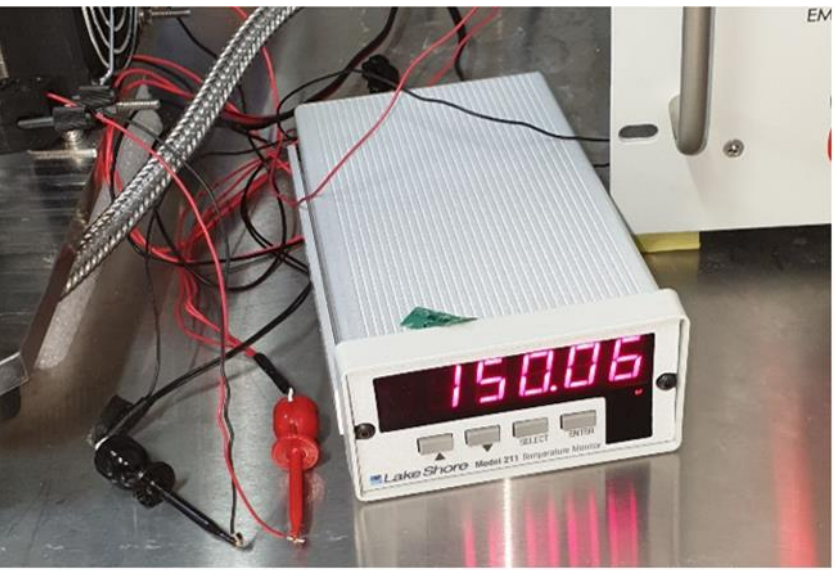

## PRESENT STATUS

V.3 SPLIT

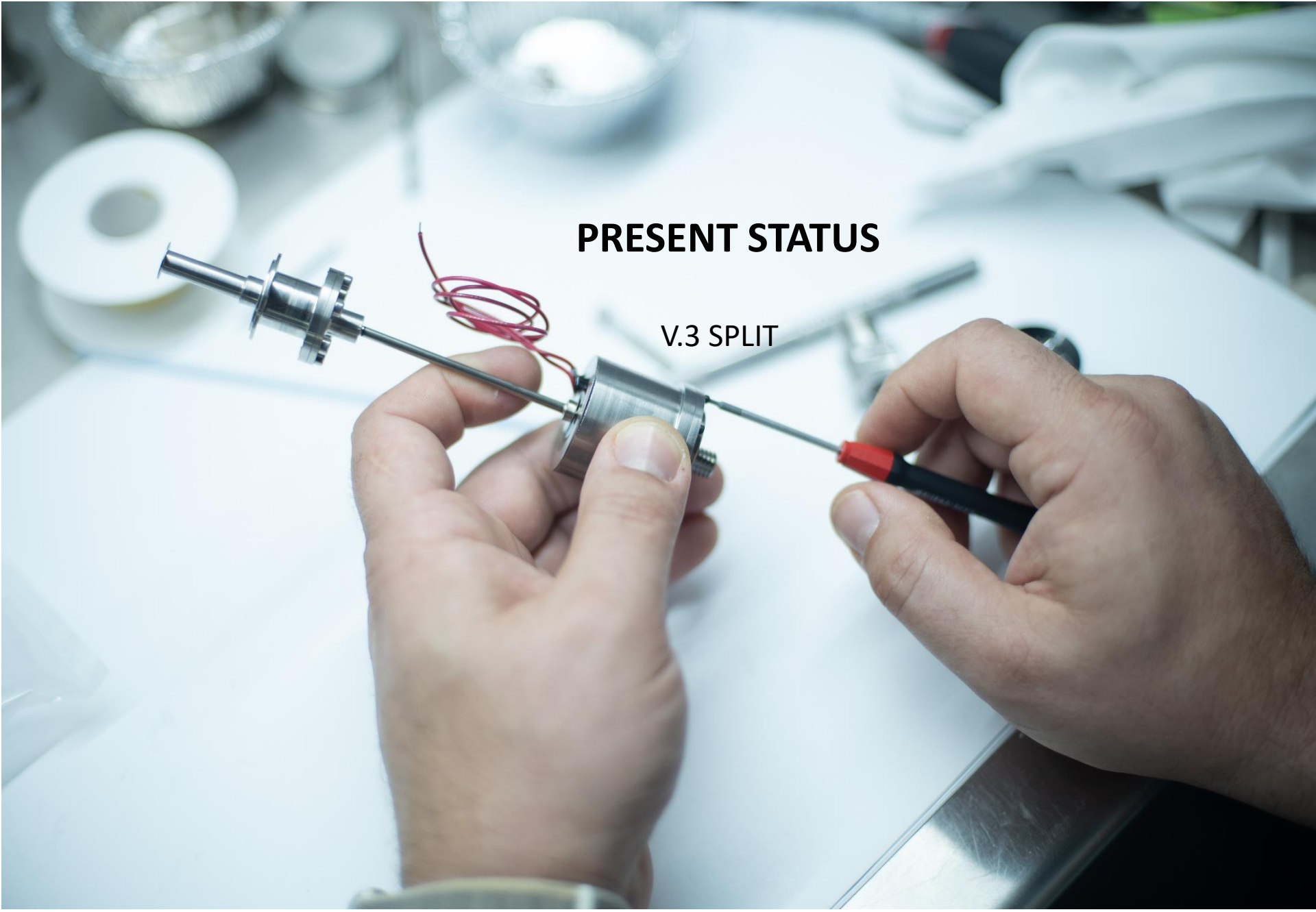

### V.3 SPLIT

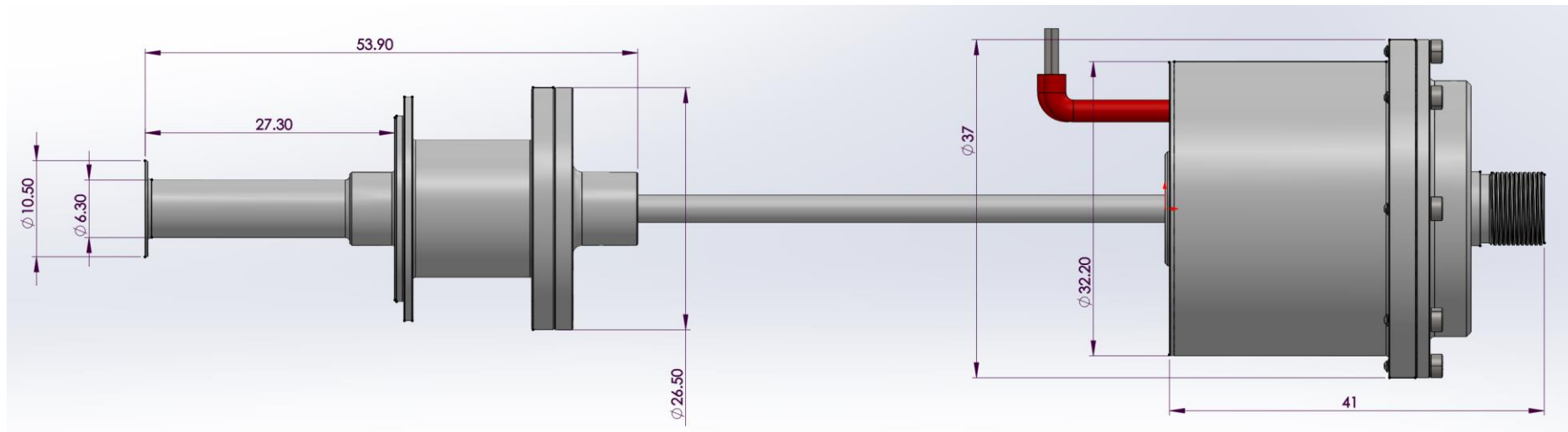

Weight: 140gr with cold finger

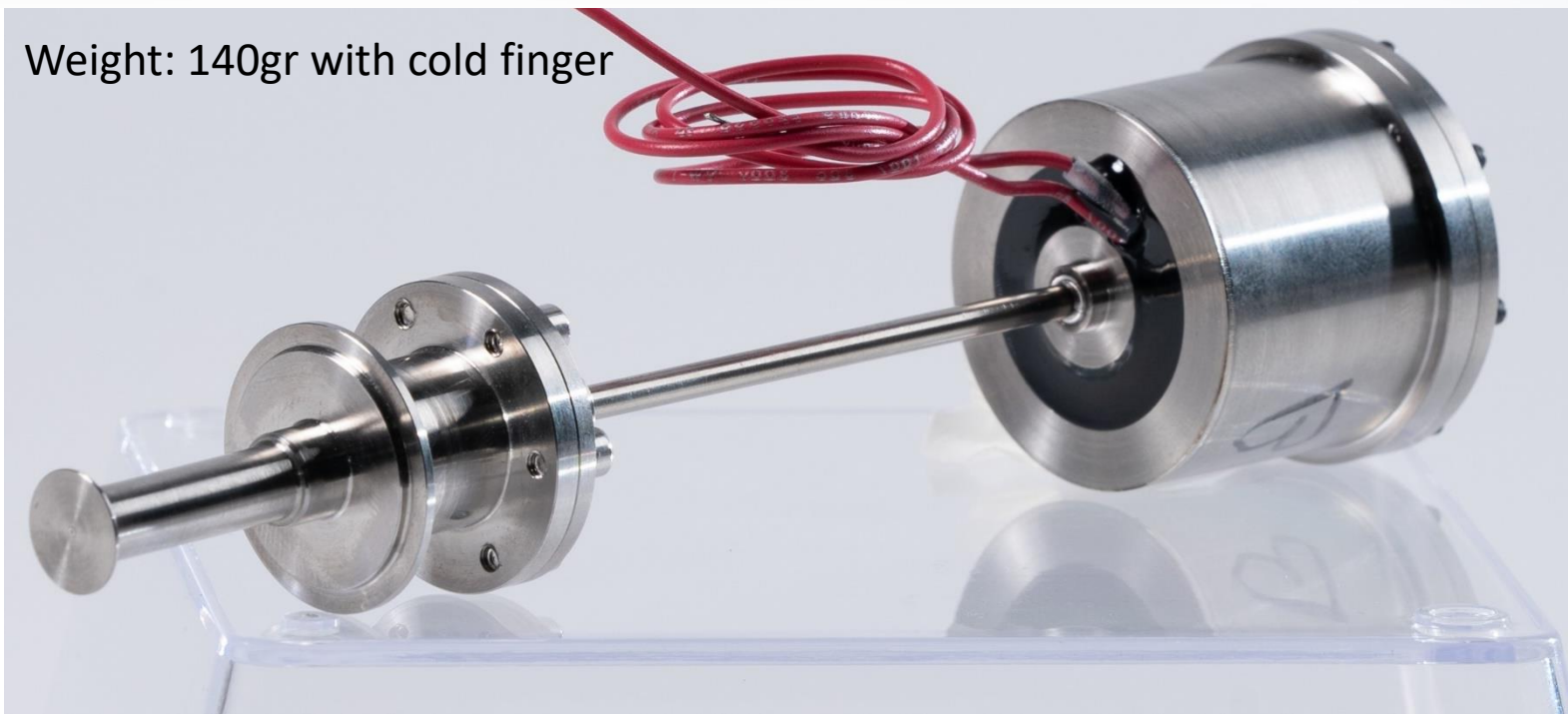

## V.3 SPLIT

- 1000 hours full power burn-in testing

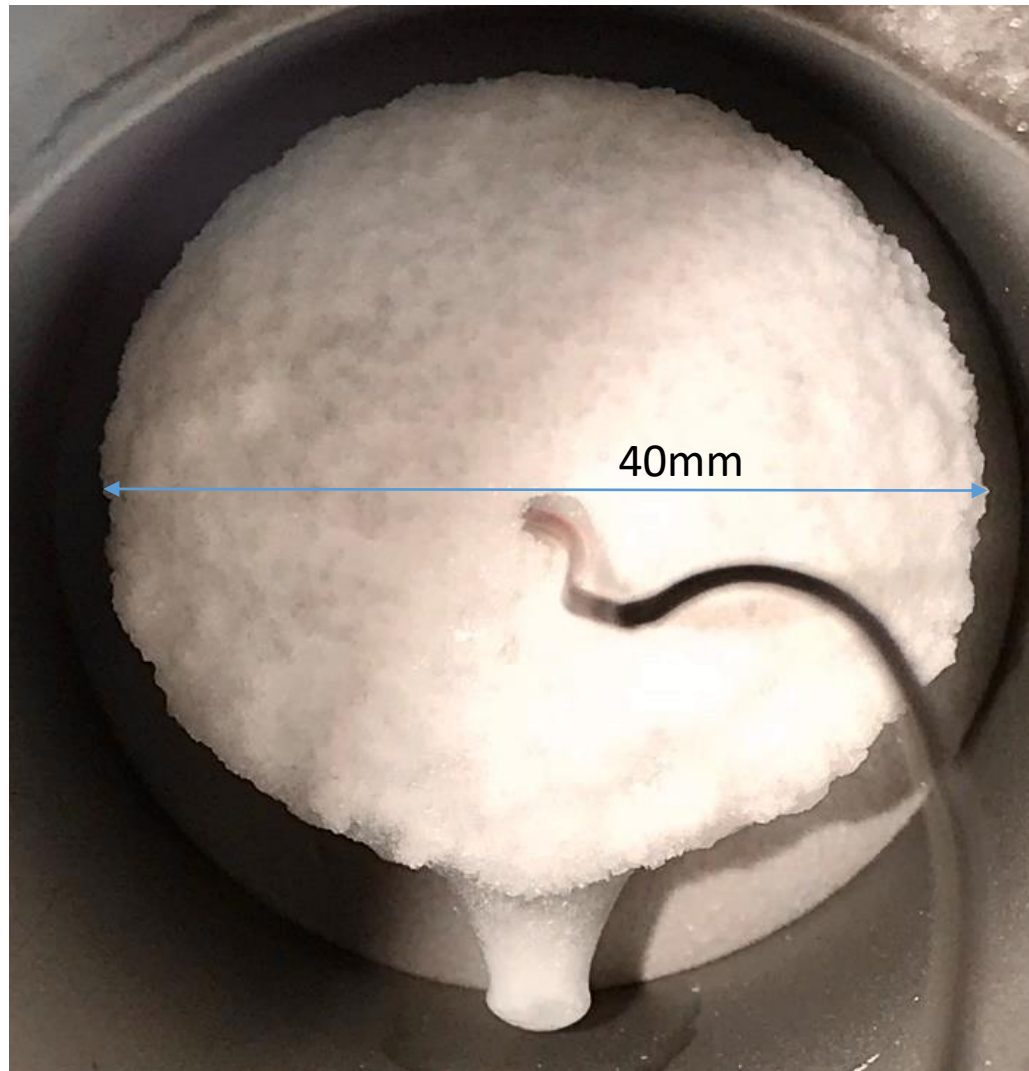

### V.3 SPLIT

### Simulation Dewar 200mW@150K@23C

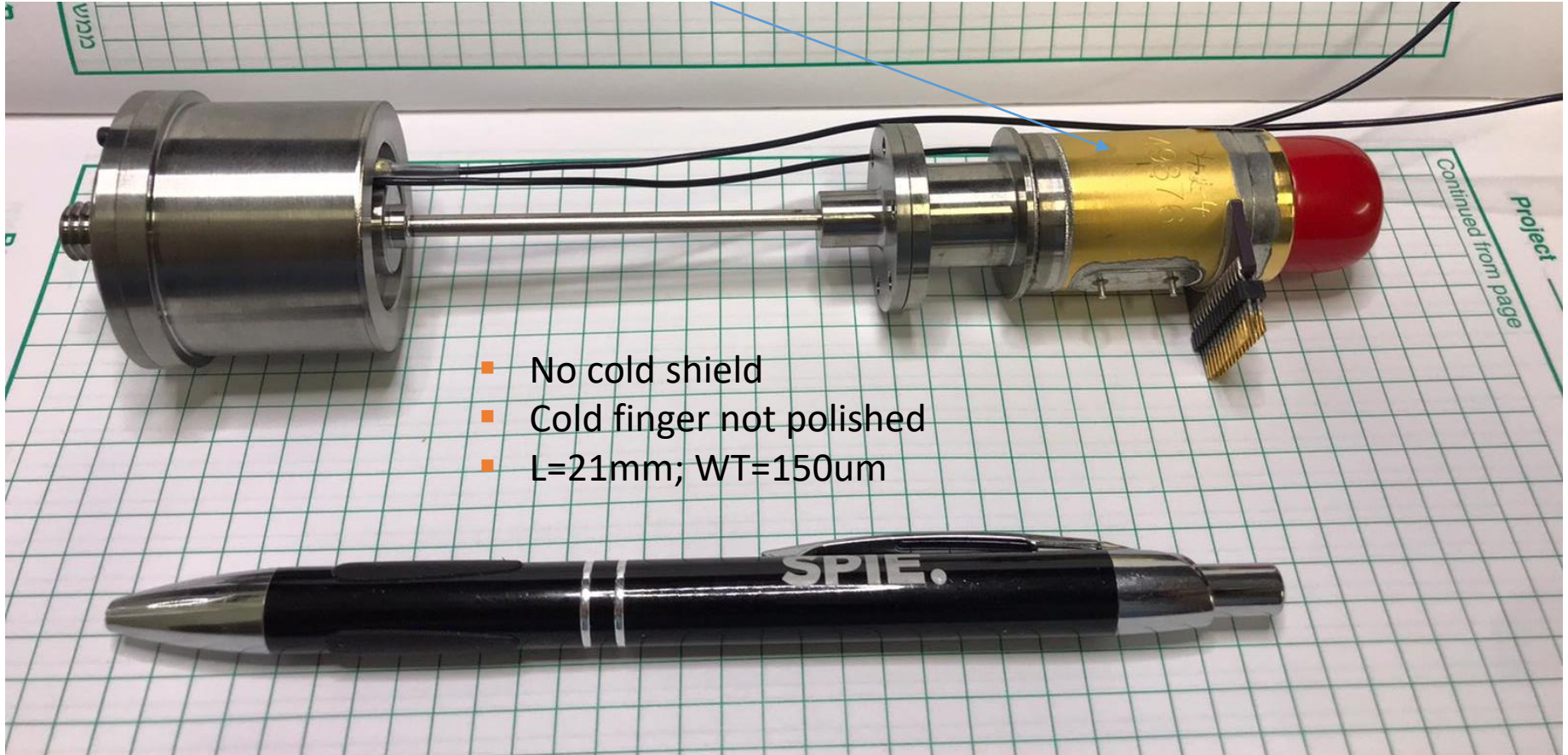

- No cold shield
- Cold finger not polished
- L=21mm; WT=150um

### Simulation Dewar heat load evaluation

- Vendor simulation tool
- Warm-up calorimetry

CF conductivity	122.6 mW
CF radiation (e=0.5)	45mW
Substrate radiation	31mW
Total	199 mW

## EVALUATION TEST BENCH



# Time to image (290 K to 160K) – 115s

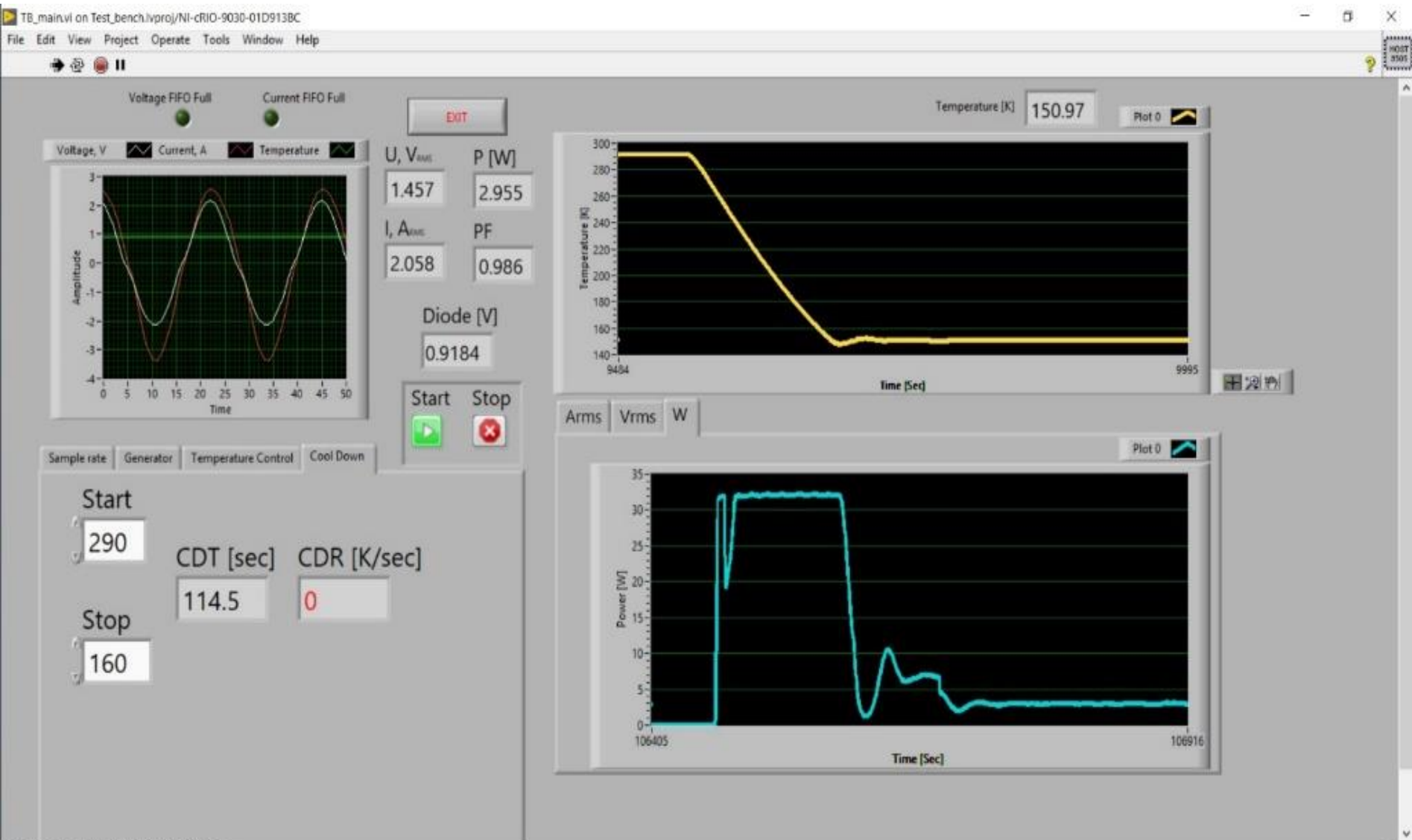

# 150K TEMPERATURE CONTROL MODE

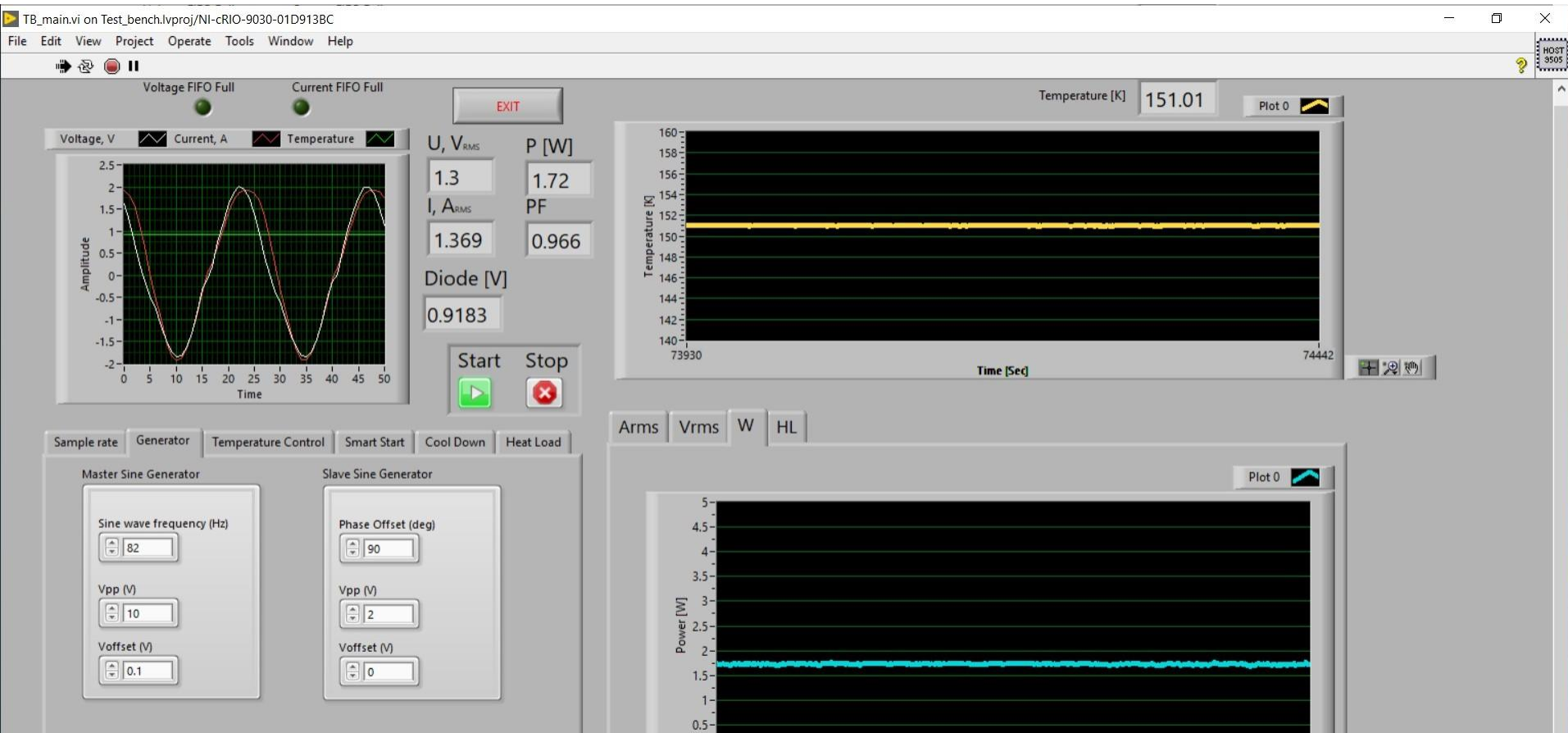

## TEMPERATURE CONTROL MODE 120 K TO 200K

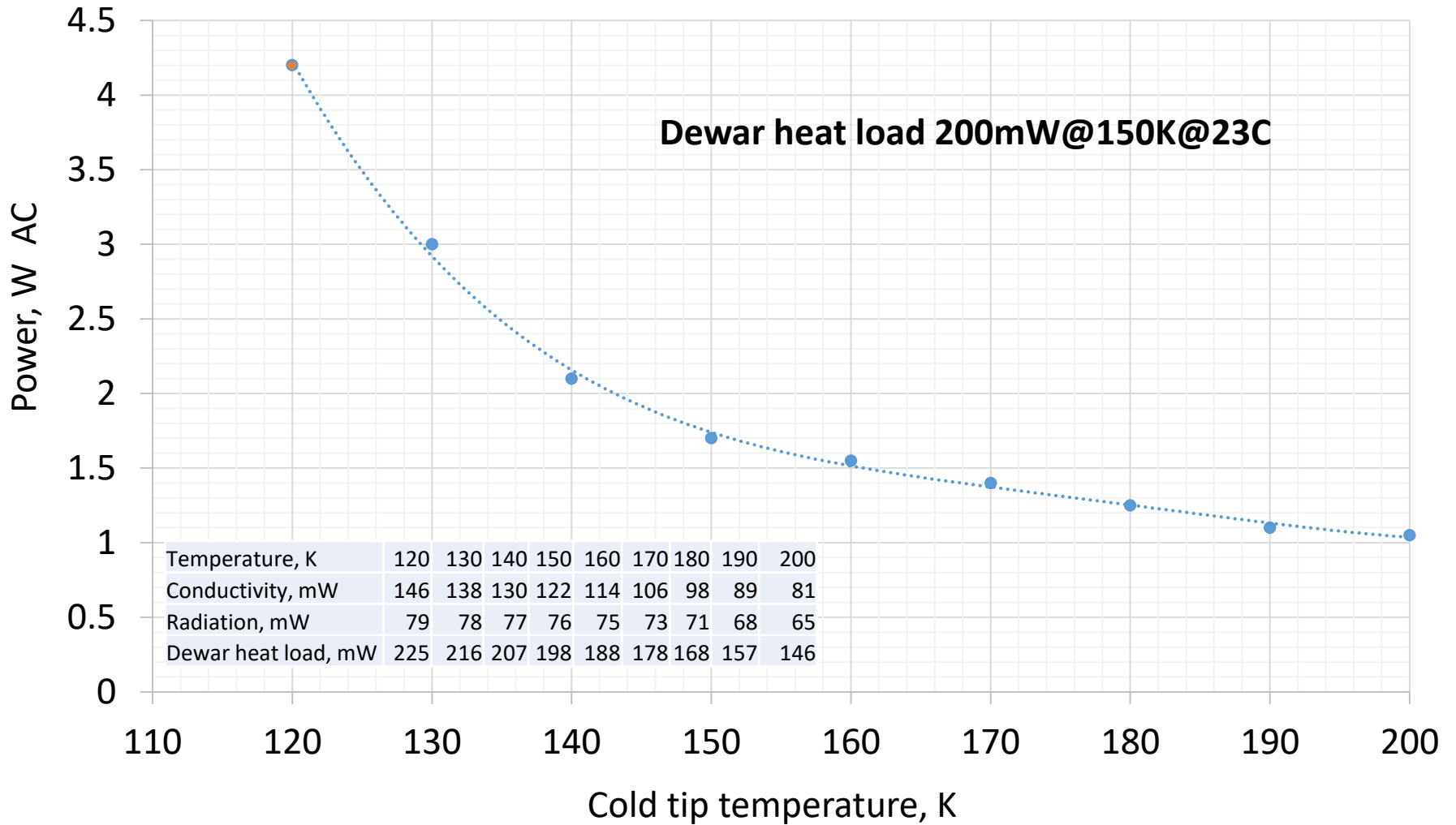

**MODIFICATIONS PRIOR TO CONFIGURATION FREEZE – V.4**

- Cold finger WT -120um
- Cold finger length (active) - 27mm
- Cold finger OD polish
- Warm side of cold head – less void volume
- Actuator redesign

Weight: 120 gr excl. cold finger

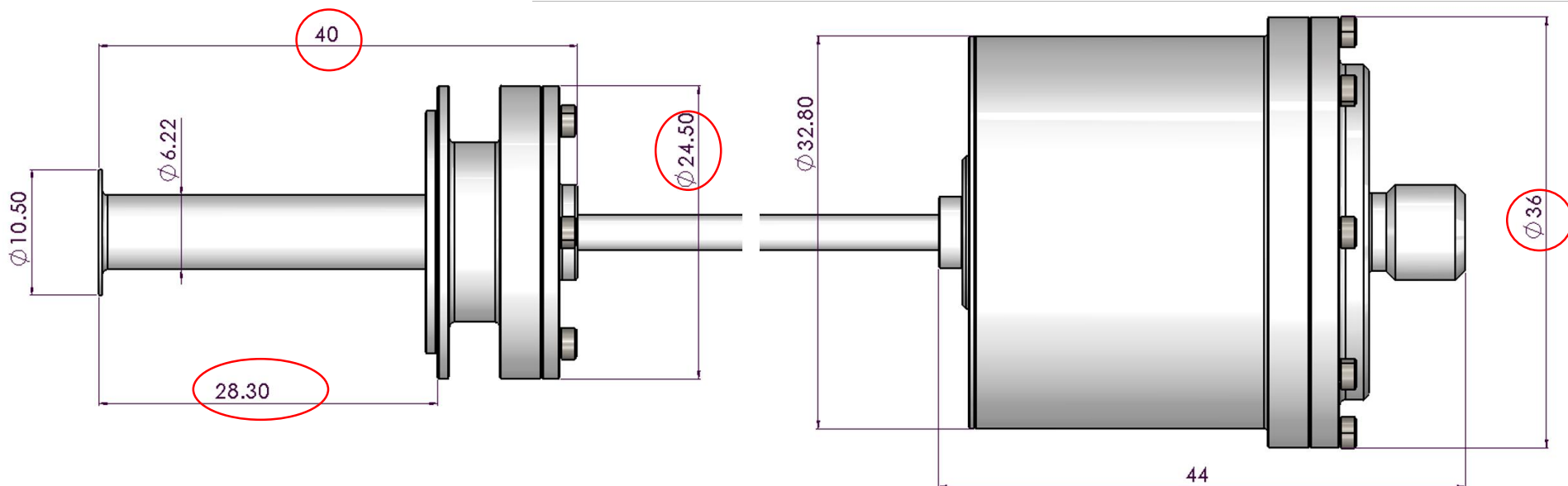

## Vibration issues – tuned dynamic counterbalancer (optional)

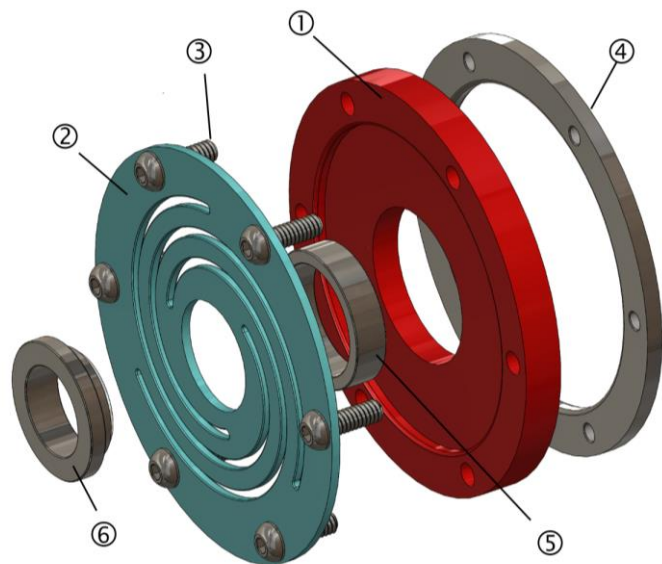

- ① proof ring
- ② planar flexural bearing
- ③ screws
- ④ threaded ring
- ⑤, ⑥ spacers

Added weight 55 gr

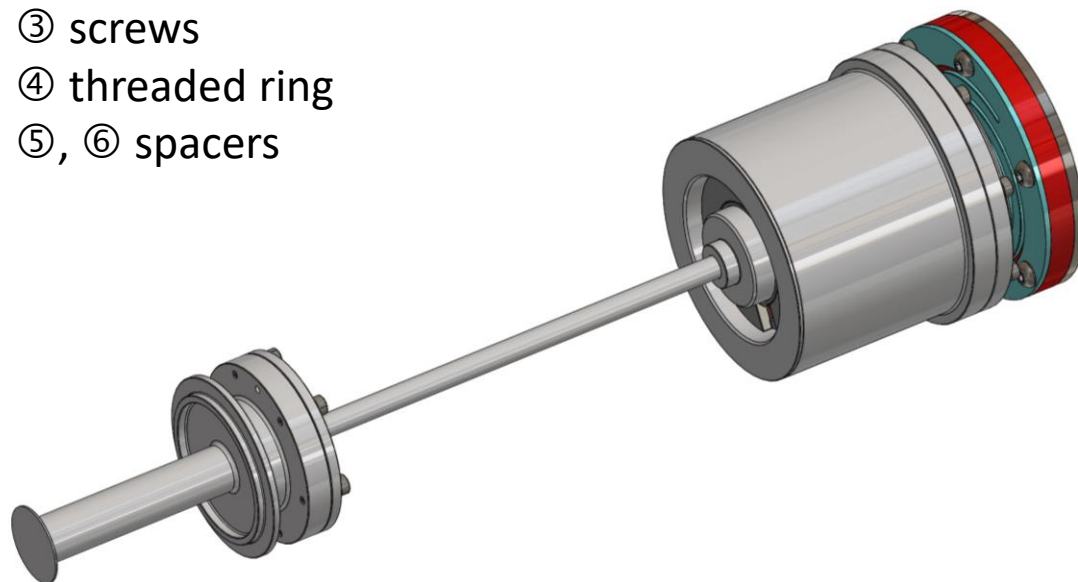

# Vibration issues

## Dynamic design

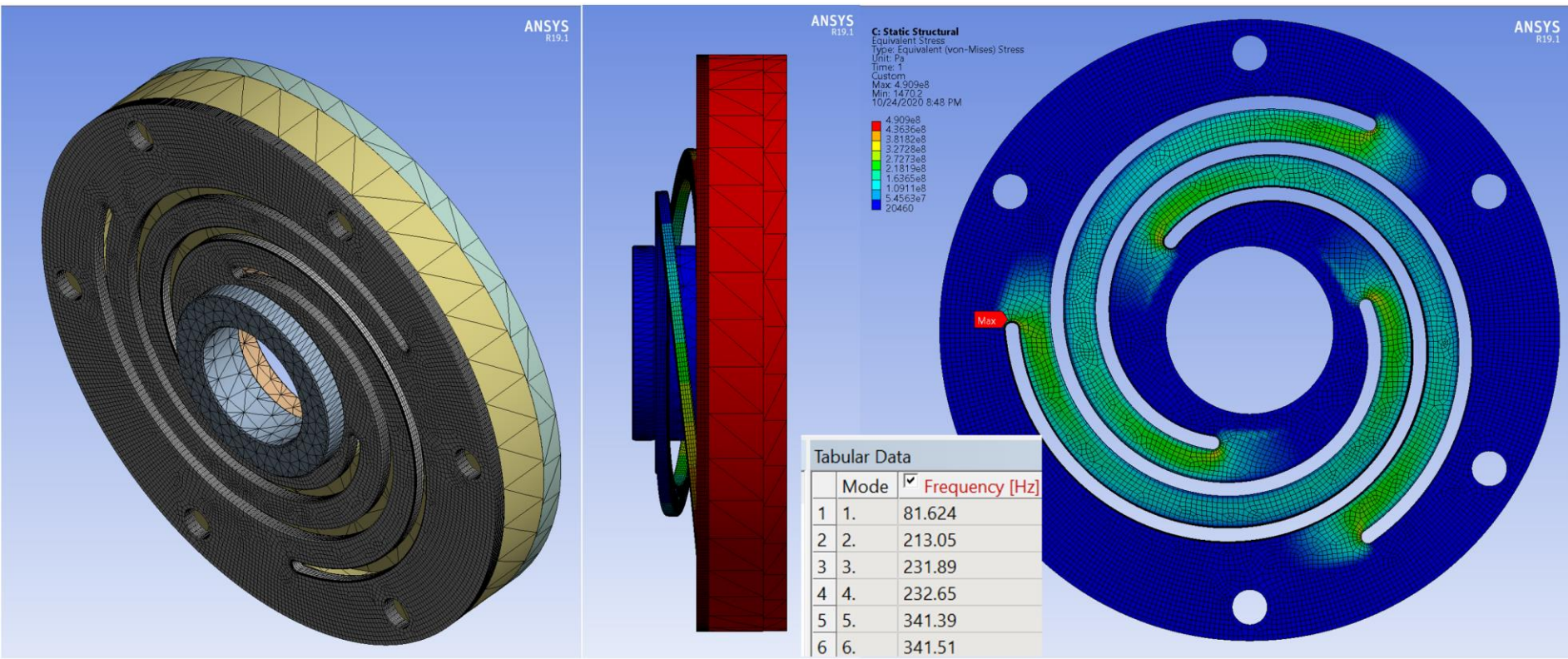

## Vibration issues

Platform weight 2kg

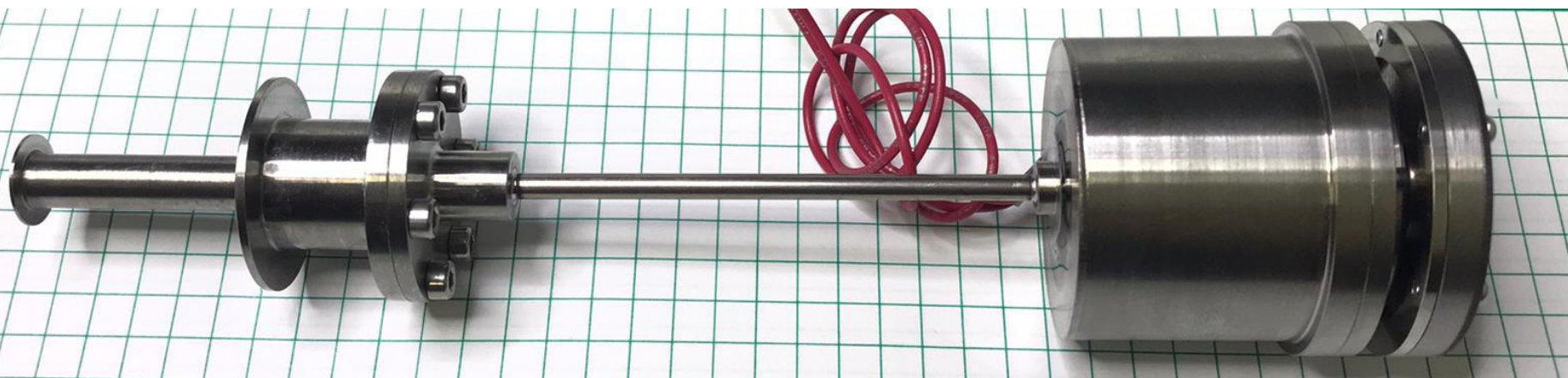
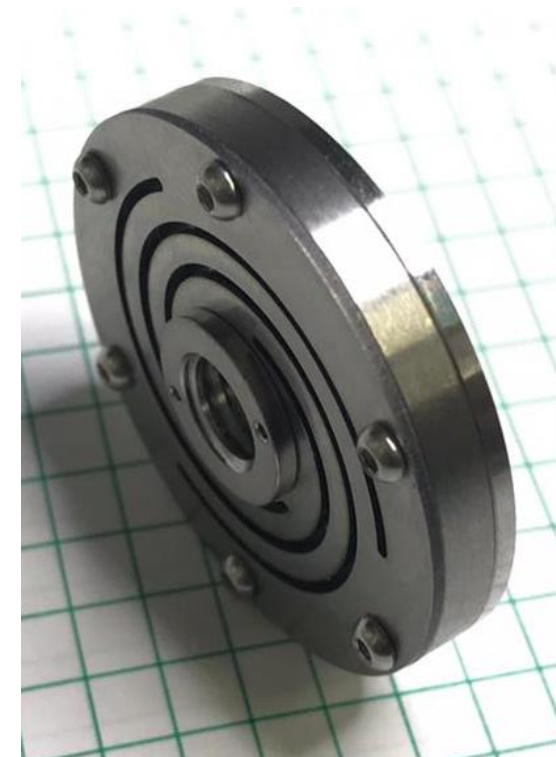
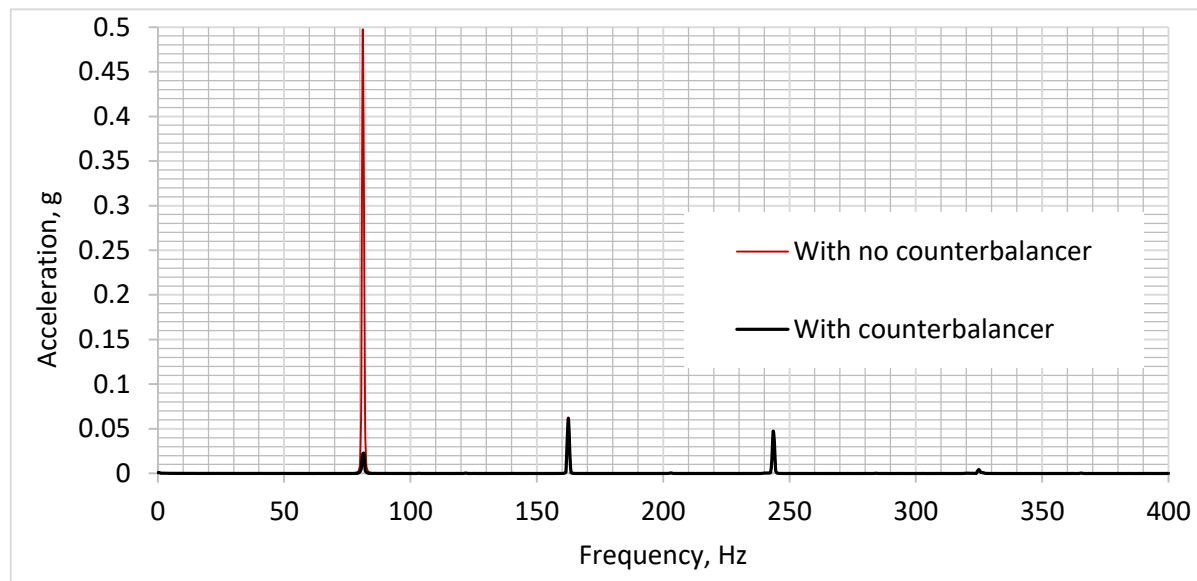

## WAY FORWARD

- Extended R&D lab inc. clean room , staffing – Apr 2021
- Manufacturing facility, staffing – Nov 2021
- Testing facility – life testing, environmental extremes – Dec 2021
- Evaluation units availability – Aug 2021